

APPLICATION MANUAL

15P0056B1

AMS90/1

Updated 01/10/98 R.01 **English**

- This manual is integrant and essential to the product. Carefully read the instructions contained herein as they provide important hints for use and maintenance safety.
- This device is to be used only for the purposes it has been designed to. Other uses should be considered improper and dangerous. The manufacturer is not responsible for possible damages caused by improper, erroneous and irrational uses.
- Elettronica Santerno is responsible for the device in its original setting.
- Any changes to the structure or operating cycle of the device must be performed or authorized by the Engineering Department of Elettronica Santerno.
- Elettronica Santerno assumes no responsibility for the consequences resulting by the use of non original spare-parts.
- Elettronica Santerno reserves the right to make any technical changes to this manual and to the device without prior notice. If printing errors or similar are detected, the corrections will be included in the new releases of the manual.
- Elettronica Santerno is responsible for the information contained in the original version of the Italian manual.
- The information contained herein is the property of Elettronica Santerno and cannot be reproduced. Elettronica Santerno enforces its rights on the drawings and catalogues according to the law.



Elettronica Santerno S.p.A.

Via G. Di Vittorio, 3 - 40020 Casalfiumanese (BO) Italy

Tel. +39 0542 668611 - Fax +39 0542 666632

After Sales Service Tel. +39 0542 668610 - Fax +39 0542 666778

Sales Office Tel. +39 051 6010231 - Fax +39 051 534403

TABLE OF CONTENTS

Standard configuration	Page	2
General features	"	3
External and fixing dimensions (fig. 1)	"	4
Power and supply connections	"	5
Signal connections	"	5
Power and supply connections diagram (fig. 2)	"	6
Signal connection diagram (fig. 3)	"	7
Size codes and extra-quick fuses table	"	8
ES719 control board description	"	9
Adjustment trimmers	"	9
Signalling LED's	"	9
Preset jumpers	"	10
Selection dip-switches	"	10
ES719 control board layout (fig. 4)	"	11
Terminal board description	"	12
Technical data table	"	13
EMI characteristics and input filter	"	14
Installation, calibration and maintenance	"	15



IMPORTANT NOTICE

If, after powering the unit, closing the run contact and sending the speed reference, the motor does not start, check that the power circuit supply at term. 23-24 has the **SAME PHASE** of the control circuit supply at term. 25-26.

If in doubt, with power circuit on (remote control switch closed, if any), check that an alternate voltage is present with a zero effective value ($\pm 200\text{mV}$) between terminals 23 and 25, and between terminals 24 and 26.

STANDARD CONFIGURATION

If no custom configuration is required, the standard configuration of the AMS90/1 drive is the following:

SUPPLY VOLTAGE: 400Vac / 50Hz.

TACHO GENERATOR FEEDBACK: 180V_{DC} max.

CURRENT LIMIT: rated value.

WARNING: before powering the unit on, check that the voltage (*TR3*, *J2*) and frequency (*SW1*) values on the plate match those of the supply mains at terminals 25-26.

GENERAL FEATURES

Application	AMS90/1 is a HALF-CONTROLLED AC/DC SINGLE-PHASE DRIVE used to supply armature and field circuits of D.C. motors, with SMT analog circuit for speed or torque control.
Supply mains	230/400V _{AC} single-phase, through voltage switching jumpers, 50/60Hz through selection dip-switches. 415/440V _{AC} voltages on demand.
Field supply	Single-phase rectifier bridge with suppression varistor.
Armature voltage	0...280V _{DC} (for 400V _{AC} mains).
Mains insulation	Galvanic type, with tacho generator feedback.
Reference supplies	Stabilized, with values ranging from +10V _{DC} to -10V _{DC} .
Speed inputs	1 direct input + 1 ramp input, through voltage reference signal 0...+10V _{DC} , with terminal board output. 1 direct input through current reference signal 4...20mA, to be selected through proper jumper setting.
Adjustments	Max. and min. speed value (min. value selectable through potentiometer). Stability. Internal or external current limit. Armature compensation. Acceleration and deceleration ramps. Speed offset.
Light indicators	Presence of supply direct voltages. Current limit reached. Zero speed. Running drive.
Auxiliary functions	Gradual acceleration and deceleration, with run automatic release. Tacho generator feedback with automatic polarity rectification. High-impedance armature feedback, with R x I drop compensation.
Current limit	Selectable through internal trimmer or external voltage 0...-10V _{DC} .
Analog outputs	Voltage signal 0...+10V _{DC} <i>V OUT</i> proportional to motor speed. Current signal 0...+10V _{DC} <i>I OUT</i> proportional to armature current.
Digital I/Os	Input for <i>RUN/STAND BY</i> control through high or low voltage level, selectable through jumper. Output with insulated relay contact, for zero speed signalling.
Room conditions	Natural ventilation. Temperature from 0 to 40°C max. with 4% derating for every degree of increase. Relative humidity 20...90% (without dew). Height: 1000m max (a.s.l.). 1% derating for every 100m increase.
Weight	2.65kg for AMS90/1.10 and .20; 3.3kg for AMS90/1.30.
Protection degree	IP20.

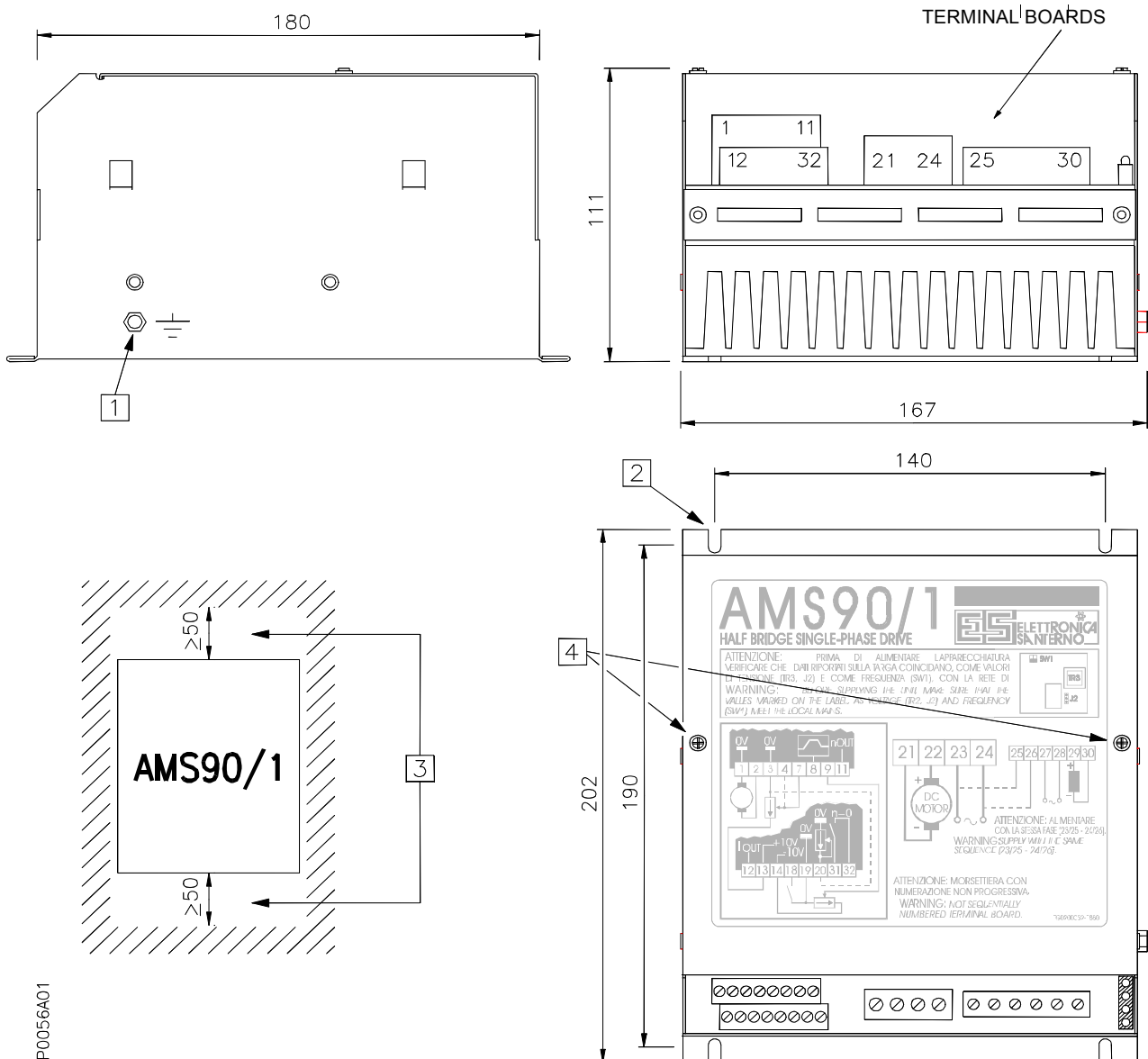

- ① Ground screw (thread M5).
- ② Fixing on vertical panel through 4 M4 screws.
- ③ Let a free space in the upper and lower side of the drive, so as the cooling air can circulate.
- ④ To access the drive inside, unscrew the two self-tapping screws 3.5x9.5 used for cover fastening.

Fig. 1 - External and fixing dimensions

POWER AND SUPPLY CONNECTIONS

(See fig. 2)

- EF** Single-phase filter against electromagnetic interference (EMI). See section EMI CHARACTERISTICS AND INPUT FILTER.
- L1/L2** Supply single-phase mains 50/60Hz (standard 400V_{AC}).
- FU1/FU2** Fast-acting fuses for AC/DC armature bridge protection.
- FU3/FU4** Delayed fuses for TC auto-transformer primary protection.
- FU5** Fast-acting fuse for field AC/DC bridge.
- FU6/FU7** 2A fast-acting fuses to protect the control circuit supply internal transformer.
- KM** Supply remote control switch for AC/D armature bridge.
- L1** Switching impedance.
- L2** Levelling impedance for form factor enhancement.
- TC** Auto-transformer (if any) for D.C. motor field supply.
The alternate voltage V_{EA} on the secondary is obtained from the direct voltage V_{EC} through the following formula:
- $$V_{EA} = V_{EC} \cdot 1.11$$
- M1** D.C. motor (armature circuit + field circuit).

Note: at term. 29-30, a 2A direct current can be delivered for field winding, for all AMS90/1 sizes. Do not exceed this value.
If the motor needs a higher current, the field circuit should be supplied **separately**.

SIGNAL CONNECTIONS

(See fig. 3)

- RP1** 2K5 potentiometer for speed reference.
- RP2** 2K5 potentiometer for current limit reference (only with AMS90/1 properly preset: see jumper J5).
- KA** Run contact.
- BR** Tacho generator.
- PV** Tacho instrument.
- PA** Ammeter instrument.
- KM** NO contact of supply remote control switch for AC/DC armature bridge.

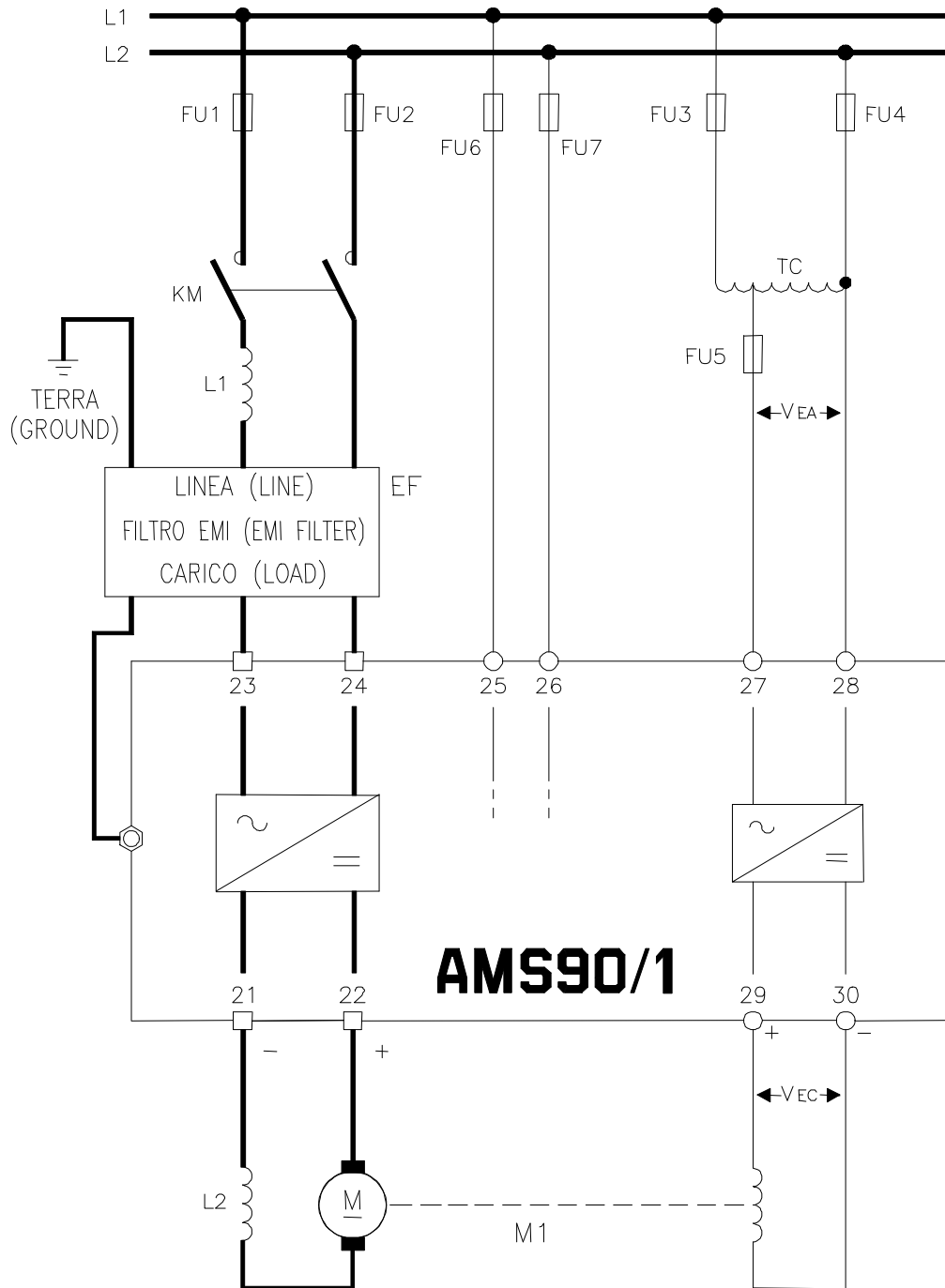

P0056A02



Connect term. 25-26 IN PHASE with term. 23-24 respectively.

Fig. 2 - Power and supply connections diagram

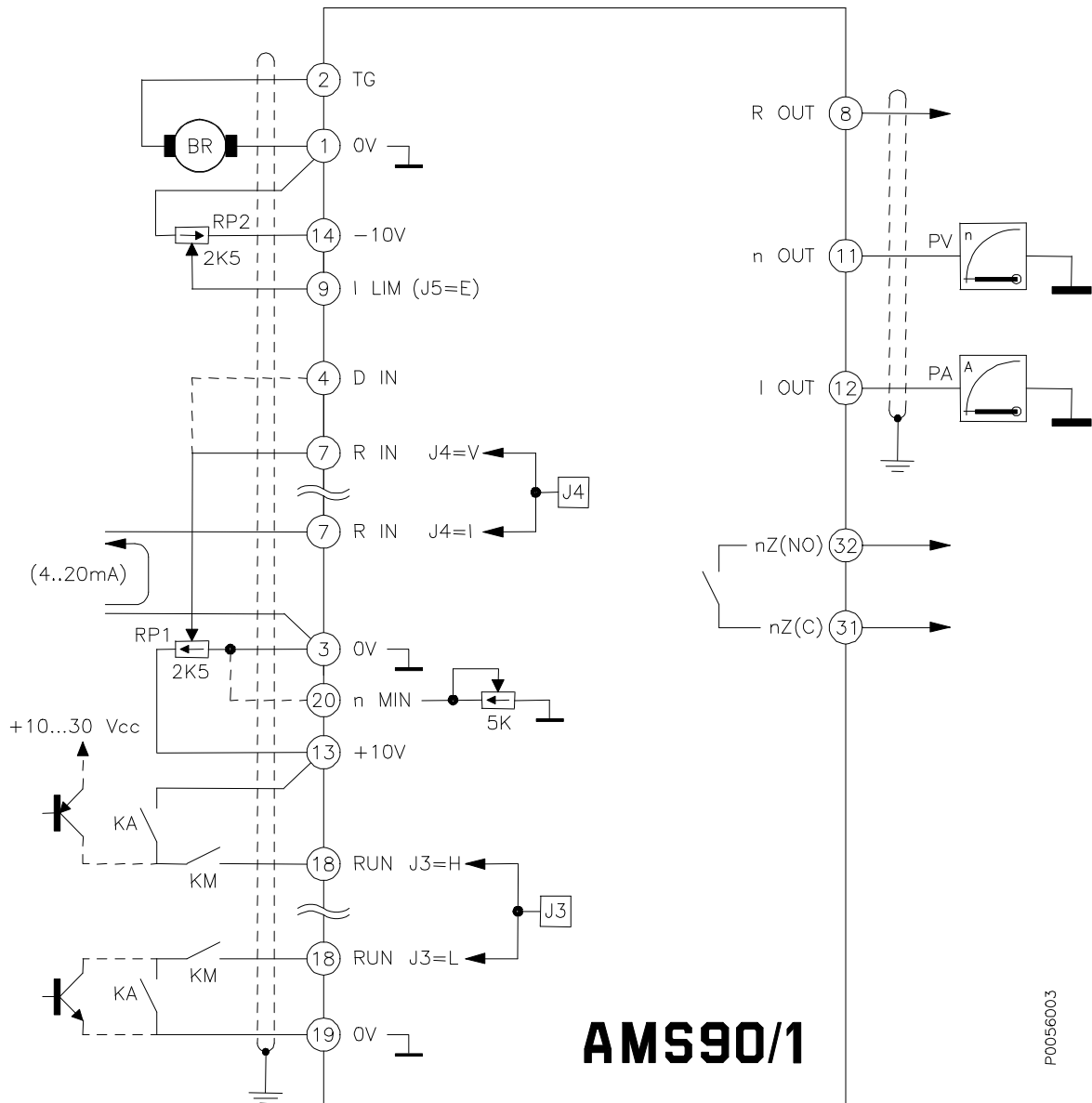

AMS90/1

P0056003

Note: to have the drive match the standards concerning radio-frequency immunity characteristics, keep 0V insulated from earth. In turn, connect the earth to cable shield, through a connection that should be as short as possible.



Always fit a NO auxiliary contact of KM remote control switch at terminal 18, as closure of KM remote control switch AFTER closure of RUN contact, if control section is already supplied at terminal 25-26, may destroy internal rectifier bridge.

Fig. 3 - Signal connection diagram

SIZE CODES AND EXTRA-QUICK FUSES TABLE

Drive	Product code	Size code	Max. mean curr. (A)	Max. allowed form factor	F.A. fuses FU1/2 (A)	Max I ² T for FU1/2 V _{ALIM} +10% (A ² s)
AMS90/1.10 supp.230V	ZZ0045020	01230	10	1,5	25	150
AMS90/1.10 supp.400V	ZZ0045020	01400				
AMS90/1.10 supp.415V	ZZ0045020	01410				
AMS90/1.10 supp.440V	ZZ0045020	01440				
AMS90/1.20 supp.230V	ZZ0045020	02230	20		25	150
AMS90/1.20 supp.400V	ZZ0045020	02400				
AMS90/1.20 supp.415V	ZZ0045020	02410				
AMS90/1.20 supp.440V	ZZ0045020	02440				
AMS90/1.30 supp.230V	ZZ0045030	03230	30		32..35	250
AMS90/1.30 supp.400V	ZZ0045030	03400				
AMS90/1.30 supp.415V	ZZ0045030	03410				
AMS90/1.30 supp.440V	ZZ0045030	03440				

WARNING: The use of extra-quick fuses FU1/2 is recommended to protect the internal power module in case of undesired external short-circuits. Comply with the max. prescribed value for I²t.

The L1 switching impedance is 35A/150μH (ELETTRONICA SANTERNO code: IM0100354).

The current FF form factor can be obtained by measuring the effective value $I_{e[a]}$ of the alternate component of the current absorbed by the motor (with a A.C. instrument with real effective value) and the mean value I_m of the same current (with a D.C. instrument). The result is given by the following formula:

$$FF = \frac{\sqrt{I_{e[a]}^2 + I_m^2}}{I_m}$$

Since the motor and drive heating, as well as the periodical maintenance operations on brushes and manifold, depend on the form factor, apply the levelling inductance L2 so as to keep the form factor value as close as possible to 1.

Through the following formula, you can get the L2 mH value of the levelling inductance to be inserted, assuming the motor one is negligible, using the desired form factor FF value, the supply alternate voltage V_a value and the mean output current I_m value:

$$L2[mH] = \frac{V_a \cdot 0.9}{I_m \cdot \sqrt{FF^2 - 1}}$$

ES719 CONTROL BOARD DESCRIPTION

(see fig. 4)

ADJUSTMENT TRIMMERS

- (RV1) **10V** Supply voltages $\pm 10V$.
Do not change.
- (RV2) **n MIN** Min. speed, selectable on the negative terminal of the RP1 speed potentiometer.
- (RV3) **STAB** Stability (PI time constant of voltage amplifier).
- (RV4) **UP** Acceleration ramp (0,5 ... 100sec).
- (RV5) **DOWN** Deceleration ramp (0,5 ... 100sec).
- (RV6) **n OUT** Signal output at term. 11, proportional to the motor rotation speed (tacho generator feedback), or to the voltage output at terminals 21-22 in case of armature feedback.
- (RV7) **I LIM** Internal current limitation.
- (RV8) **COMP** Compensation for armature drop $R \times I$.
Note: in case of tacho generator feedback, keep it in CCW position.
- (RV9) **n MAX** Max. speed.
Tacho generator feedback: selectable within the range 40...230V_{DC} at term. 1-2.
Armature feedback: selectable within the range 55...325V_{CC} at term. 21-22.
- (RV10) **n OFS** Speed amplifier offset: the correct adjustment of this trimmer avoids speed drift with zero reference and, at the same time, an area insensitive to minimum references. **Change it only if required: see section CALIBRATION.**

SIGNALING LEDS

- (L1) **15V** Presence of $\pm 15V_{dc}$ supply voltages.
- (L2) **n=0** Motor at zero speed.
- (L3) **RUN** Operation enabling.
- (L4) **LIM** Drive in current limitation.

... cont.

... *cont.* **ES719 CONTROL BOARD DESCRIPTION**
(see fig. 4)

PRESET JUMPERS

(Pos. STANDARD: **J2** \mathbf{P} 400, **J3** \mathbf{P} L, **J4** \mathbf{P} V, **J5** \mathbf{P} I)

J2 pos. 230 230Vac supply at terminals 25 and 26.

J2 pos. 400 400Vac supply at terminals 25 and 26.

NOTE: If required, our transformer with code TR0102121 (instead of TR0102122) can be installed as transformer TR3 to supply with voltage the terminals 25 and 26, according to the position of jumper J2, 415Vac or 440Vac.

J3 pos. L Drive enabling at term. 18 (RUN) closing towards 0V, through insulated relay contact or NPN transistor.

J3 pos. H Drive enabling at term. 18 (RUN) closing towards a positive voltage of 0...30V_{DC}, through insulated relay contact or NPN transistor.

J4 pos. V Term. 7 configured as ramp input for a voltage speed reference of 0...+10V_{DC}.

J4 pos. I Term. 7 configured as ramp input for a current speed reference of 4...20mA (current **output** from term. 7).

J5 pos. I Inner adjustment of current limit.

J5 pos. E External control of current limit.

SELECTION DIP-SWITCHES

(Pos. STANDARD: **SW1(1+2)** \mathbf{P} OFF, **SW2(1+2+3+4)** \mathbf{P} OFF)

SW1 contacts 1+2 \mathbf{P} OFF Presetting for mains supply with 50Hz frequency.
(bottom contacts)

SW1 contacts 1+2 \mathbf{P} ON Presetting for mains supply with 60Hz frequency.
(top contacts: 60)

SW2 contacts 1+2+3+4 \mathbf{P} OFF Presetting for tacho generator feedback at
(bottom contacts) terminals 1 and 2.

SW2 contacts 1+2+3+4 \mathbf{P} ON Presetting of armature feedback, at high
(top contacts: ARM) impedance. In this case, the tacho generator signal should NOT be present at term. 1 and 2.

Note: act on contacts SW2 only when term. 25-26 are NOT supplied.

Note: under TACHO GENERATOR feedback, if you close **only** the key no. 4 (the right one) of SW2, you LOWER the max. speed range, which can be obtained through trimmer RV9 (n MAX) – up to 16...92V_{DC} at term. 1-2.

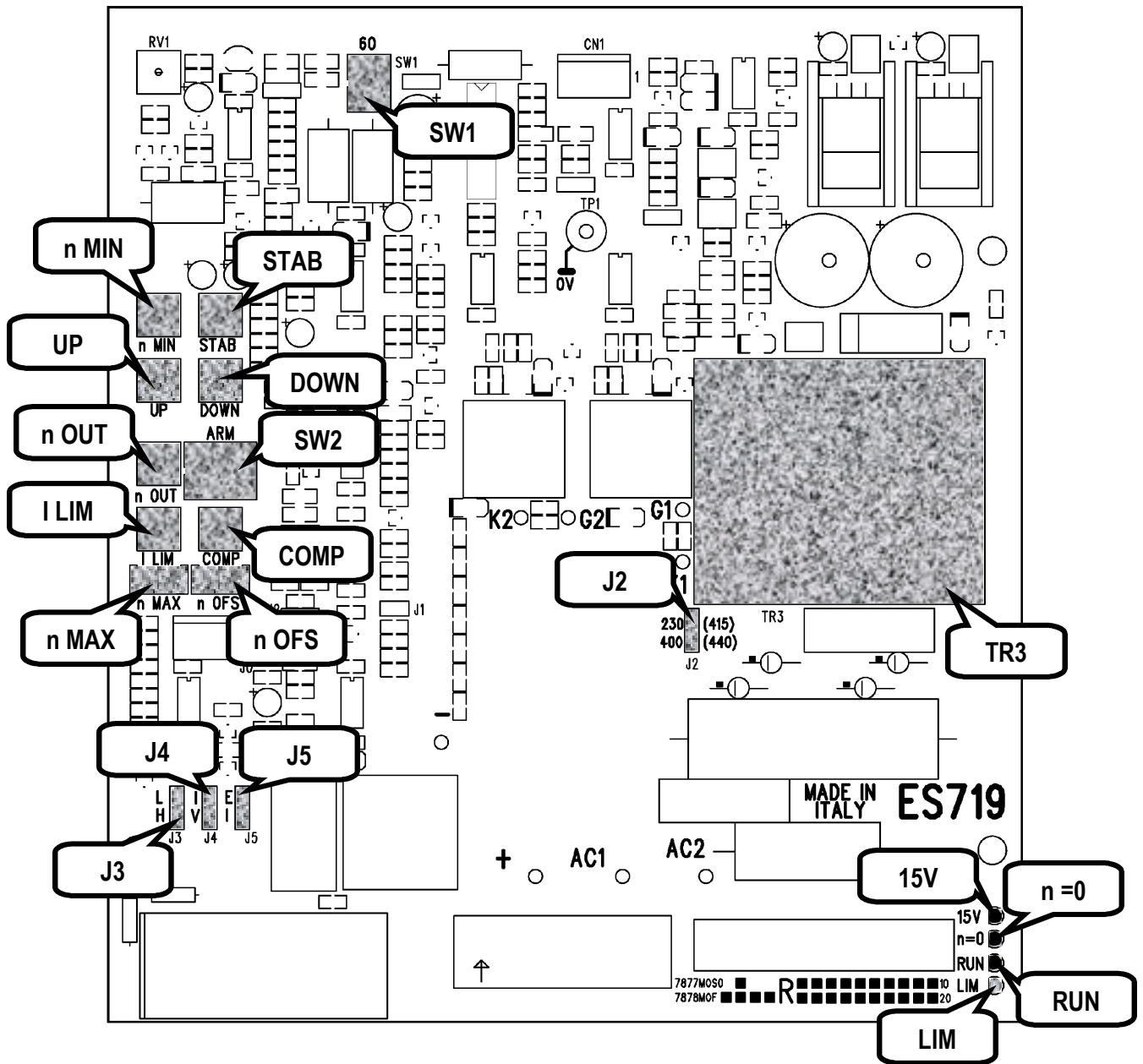

Fig. 4 - ES719 control board layout

TERMINAL BOARD DESCRIPTION

SIGNAL TERMINAL BOARD

1	0V	0V	
2	TG	Input for tacho generator feedback	$R_{in} \approx 107k\Omega$
3	0V	0V	
4	D IN	Input for direct reference 0...+10V _{CC}	$R_{in} \approx 10k\Omega$
7	R IN	With J4 in pos. V : ramp input for voltage signal 0...+10V _{DC} . With J4 in pos. I : direct input for current signal 4...20mA.	J4 P V : $R_{in} \approx 107k\Omega$ J4 P I : $R_{in} \approx 107k\Omega$
8	R OUT	Ramp circuit output 0...+10V _{DC}	+10V _{DC} max (6mA max)
9	I LIM	With J5 in pos. I : terminal not connected. With J5 in pos. E : input for external setting of current limit 0...-10V _{DC} . A reference of -10V _{DC} can be used to set the AMS90/1 rated current.	$R_{in} = 10k\Omega$
11	n OUT	Speed signal output (voltage) for tacho (voltmeter) or for cascade reference distribution. Adjustable through trimmer RV6 up to 10V _{DC} . STANDARD calibration: +10V _{DC} at max. speed.	+10V _{DC} max (6mA max)
12	I OUT	Current signal output for possible ammeter. STANDARD calibration: +10V _{DC} at drive rated current.	+10V _{DC} max (6mA max)
13	+10V _{CC}	Supply output for +10V _{DC} reference.	(6mA max)
14	-10V _{CC}	Supply output for -10V _{CC} reference.	(6mA max)
18	RUN	With J3 in pos. L : the drive is operated if term. 18 is connected to 0V (through insulated relay contact or NPN transistor output). With J3 in pos. H : the drive is operated if term. 18 is connected to a positive voltage 10...30V _{DC} (through insulated relay contact or NPN transistor output).	J3 P L : 12V _{DC} / 1.2mA J3 P H : 0.5mA con 10V _{DC} 1.9mA con 30V _{DC}
19	0V	0V.	
20	n MIN	Resistive limit switch on negative end (CCW) of speed potentiometer, for min. reference.	$R_{in} \text{ max} = 10k\Omega$
31	nZ(C)	NO contact of inner relay signalling motor at zero speed.	
32	nZ(NO)	The relay is energized at stopped motor, by closing contact at term. 31-32. The relay switching usually occurs at 2.1% of max. speed.	250V _{AC} / 1250VA

... cont.

... cont. **TERMINAL BOARD DESCRIPTION**

POWER TERMINAL BOARD

21	D.C. supply output for armature winding.
22	Positive polarity on term. 22.
23	Single-phase supply (STANDARD 400V _{AC}) for AC/DC conversion bridge.
24	If required, 415/440V _{AC} supply voltages are available.

SUPPLY TERMINAL BOARD

25	Single-phase supply (STANDARD 230/400V _{AC} – 50Hz with voltage change jumper).	
26	Supply frequency 60Hz with presetting by closing the two contacts of dip-switch SW1. Note: If required, 415/440V _{AC} supply voltages are available.	
		10VA
27	Single-phase supply (STANDARD 400V _{AC} max) for inner rectifier for field winding.	400V _{AC} max 2A max
28		
29	D.C. supply output for field winding.	360V _{DC} max 2A max
30	Positive polarity on term. 29.	

TECHNICAL DATA TABLE

AMS90/1 size	Rated current (A)	Max. armature voltage (V)	Output electric power (kW)	Motor power ($\eta=0.8$) (HP)
AMS90/1.10 supp. 230V _{AC}	10	170	1.7	1.8
AMS90/1.10 supp. 400V _{AC}	10	280	2.8	3
AMS90/1.20 supp. 230V _{AC}	20	170	3.4	3.7
AMS90/1.20 supp. 400V _{AC}	20	280	5.6	6
AMS90/1.30 supp. 230V _{AC}	30	170	5.1	5.5
AMS90/1.30 supp. 400V _{AC}	30	280	8.4	9.1

EMI CHARACTERISTICS AND INPUT FILTER

Radio-frequency interferences (RFI) can be generated in the area where the drive is installed. The interferences can occur both on the air (irradiated interferences), and through the power and signal cables (conducted interferences). Sometimes, due to these interferences, the drive can operate improperly, even if the AMS90/1 unit is provided with a high noise immunity and complies with the EMI standards. Also, the drive itself can produce interferences due to switching over of power semi-conductors representing its output stage.

A malfunction can be detected in the devices installed close to the drive or connected at the same supply or earth conductor.

To eliminate any interference that can affect the drive operation, proceed as follows:

- keep the drive power cables separated from the signal cables;
- use shielded cables for drive control signals and connect the shield to ground, as shown on the connection diagram; for shield grounding, choose the shortest connection, that should be direct and without any intermediate connection;
- always install anti-noise filters on the coils of remote control switches, solenoid valves, etc.

IMMUNITY TESTS OF AMS90/1	
Electrostatic discharges:	level 3 EN 61000 - 4 - 2
Burst:	level 3 EN 61000 - 4 - 4
Surge:	level 3 EN 61000 - 4 - 5
Radio-frequency electromagnetic fields:	10V/m IEC 1000 - 4 - 3

If malfunctions are detected in the devices installed close to the drive, take the following precautions:

- install the drive input filter;
- keep the drive power cables separated from any other cable;
- use shielded cables to connect sensors, instruments, etc.
- install any noise-sensitive devices as far as possible away from the drive.

WARNING! THE CONNECTION CABLES BETWEEN FILTER AND DRIVE SHOULD BE AS SHORT AS POSSIBLE.

Here is a list of the filters recommended for the different drive models, so that the conducted and irradiated interferences are included within the levels conforming to EN55011 class B and VDE0875G (civil environment) standards. **On the contrary, these filters are not required for industrial environments, where the switching inductance is enough.**

Drive type	Filter type	Rated voltage (V)	Rated current (A)	Filter code
AMS90/1.10 supp. 230Vac max	FLTA-B 1,5M	250 at 50/400 Hz	2 x 12	AC1710220
AMS90/1.20 supp. 230Vac max	FLTA-B 2,2M	250 at 50/400 Hz	2 x 24	AC1710320
AMS90/1.30 supp. 230Vac max	FLTA-B 11T (*)	460 at 50/60 Hz	2 x 30	AC1710305
AMS90/1.10 supp. 440Vac max	FLTA-B 4T	460 at 50/60 Hz	3 x 10	AC1710105
AMS90/1.20 supp. 440Vac max	FLTA-B 11T	460 at 50/60 Hz	3 x 30	AC1710305
AMS90/1.30 supp. 440Vac max	FLTA-B 11T (*)	460 at 50/60 Hz	3 x 30	AC1710305

(*) Use just two of the three lines available on the filter.

INSTALLATION, CALIBRATION AND MAINTENANCE

PRELIMINARY CONTROLS

After receiving the drive, check it carefully in order to verify the presence of damages due to transport. If so, take the necessary measures. Check that all the rating corresponds to the application, as shown on the cover label.

If not, contact your dealer or ELETTRONICA SANTERNO.

INSTALLATION

The drive must be positioned so as to allow for air circulation in vertical direction. See fig. 1: *External and fixing dimensions*.

When connecting the unit, comply with the following precautions:

1. Avoid positioning the wires of the tacho generator and of signals close to the power cables and other possible electromagnetic trouble sources. If more accuracy is required in the control system, use shielded cables externally insulated for speed reference and tacho generator feedback. The shield must be connected in the shorter and more direct way to the ground, without any intermediate connection.
2. Make connections as short as possible.
3. After wiring, check if connections and solderings are correct and check the proper positioning of jumpers and dip-switches, as regards the supply voltage and frequency and the drive application.
4. Supply the control section at terminals 25 and 26 and check that LEDs (L1) **15V** and (L2) **n=0** are on.
5. After supplying the field rectifier circuit at terminals 27 and 28, check the presence of the direct voltage required for D.C. motor field supply at terminals 29 and 30.
6. Close the KM remote control switch and the KA contact (if any) connected in series to the NO auxiliary contact of the remote control switch, and check that LED (L3) **RUN** is turned on.
7. Send the speed reference to term. 7 (or 4) and check the motor is started. If this does not happen and the LED (L4) **LIM** turns on, check if this condition is caused by one of the following reasons:
 - a) The supply of term. 25-26 IS NOT IN PHASE with that of term. 23-24 (with closed remote control switch, a zero alternate voltage should be present between term. 23 and 25, and term. 24 and 26).
 - b) An interruption occurred in one of the extra-quick fuses FU1-2 or in the armature connection.
 - c) Trimmer RV7 (*I LIM*) is fully rotated in counter-clockwise position (current limit is zero).
 - d) The drive is preset for external current limit ($J5 \Rightarrow E$) and no negative voltage is applied to term. 9.

... cont.

... *cont.* **INSTALLATION, CALIBRATION AND MAINTENANCE**

CALIBRATION

The drive is usually delivered with preset calibrations, according to the data received when ordering the unit, or based on the STANDARD CONFIGURATION.

If calibration data have to be checked or changed, proceed as follows:

a) Reduction of current limit below rating value:

1. Disconnect one of the two cables powering term. 27-28 and insulate it.
2. Connect an instrument for motor armature D.C. measurement.
3. Send a speed reference with intermediate value, close the line remote control switch and the RUN contact.
4. Check the armature current value through the previously connected instrument, and, if required, adjust the current value by rotating trimmer (RV7) **I LIM**. The value shown by the instrument must reach the required continuous value.
5. If an ammeter is connected to terminal 12, check for data consistency, always remembering that the unit sends a +10V_{DC} signal at rated current (10, 20 or 30A, depending on the circumstances).

IMPORTANT: The last two operations should be performed in the shortest time. Finally, reset the supply of the field rectifier circuit (term. 27-28).

b) Maximum speed calibration

1. Start the machine by pressing the start push-button.
2. Rotate the speed potentiometer to the max. value.
3. Turn trimmer (RV9) **n MAX** so that the machine speed is at max. value, and check that motor rating data, that is max. speed and max. armature voltage, is not exceeded.

c) Speed ramp adjustment

1. Rotate the potentiometer to the max. value.
2. Start the drive.
3. If the time required by the drive to reach the maximum speed (voltage) is too short or too long, rotate trimmer (RV4) **UP**. Otherwise, use trimmer (RV5) **DOWN** to adjust the slope. Note: the drive can control the slope only if the set ramp is longer than the normal inertia slope (i.e. the one obtained through idle stop). Further, it can control the rise, provided that it does not enter the current limit condition, i.e. provided that the rise ramp is not too short.

... *cont.*

... cont. **INSTALLATION, CALIBRATION AND MAINTENANCE**

d) Stability calibration

Connect the speed potentiometer to the direct input at term. 4 and suddenly increase the reference. Then, adjust trimmer (RV3) **STAB** so that the new speed value is reached without excessive overshoot with a long settling time, and without too quick and unstable dampings. In the first case, rotate the trimmer in CW direction, otherwise rotate it CCW.

e) Calibration of Rxl compensation (without tacho generator only).

Adjust trimmer (RV8) **COMP** to minimize the speed loss that occurs in motor when the load requires an increase of torque and absorbed current.

Note: an excessive adjustment may cause instability.

f) Speed offset calibration

If, with potentiometer at zero speed, the motor rotates slowly (unless a min. reference has been applied to the potentiometer negative end), carefully rotate trimmer (RV10) **n OFS** in CCW direction and stop the motor.

Note: an excessive adjustment may introduce an initial not-sensitive area in the speed reference adjustment scale.

MAINTENANCE

The drive maintenance is mainly a matter of periodical checking.

The first precautions against troubles due to malfunction, are the cleanliness of the machine and its installation in an environment free of vibrations and not too hot. All this will allow for a long life of all components.

A prompt attention to any trouble, even the smallest ones, detected during periodical inspections, will certainly help for drive longlife and avoid expensive operation breaks.

EC DECLARATION OF CONFORMITY

Elettronica Santerno S.p.A.
Via G. Di Vittorio, 3 - 40020 Casalfiumanese (BO) - Italy

AS MANUFACTURER

DECLARE

UNDER OUR SOLE RESPONSABILITY

THAT THE MONODIRECTIONAL HALF-CONTROLLED SINGLE-PHASE AC/DC CONVERTER
OF **AMS90/1** TYPE, AND RELATED ACCESSORIES,
TO WHICH THIS DECLARATION RELATES, APPLIED UNDER CONDITIONS SUPPLIED IN THE
USER'S MANUAL,

CONFORMS TO THE FOLLOWING STANDARDS OR NORMATIVE DOCUMENTS:

EN61800-3	Adjustable speed electrical power drive systems. Part 3: EMC product standard including specific test methods.
EN55011	Limits and methods of measurement of radio disturbance characteristics of industrial, scientific and medical (ISM) radio-frequency equipment.
EN61000-4-2	Electromagnetic compatibility (EMC). Part 4: Testing and measurement techniques. Section 2: Electrostatic discharge immunity test. Basic EMC Publication.
EN61000-4-4	Electromagnetic compatibility (EMC). Part 4: Testing and measurement techniques. Section 4: Electrical fast transient/burst immunity test. Basic EMC Publication.
EN61000-4-5	Electromagnetic compatibility (EMC). Part 4: Testing and measurement techniques. Section 5: Surge immunity test.
EN61000-4-8	Electromagnetic compatibility (EMC). Part 4: Testing and measurement techniques. Section 8: Power frequency magnetic field immunity test. Basic EMC Publication.
IEC1000-4-3	Electromagnetic compatibility (EMC). Part 4: Testing and measurement techniques. Section 3: Radiated, radio-frequency, electromagnetic field immunity test.

FOLLOWING THE PROVISIONS OF ELECTROMAGNETIC COMPATIBILITY DIRECTIVE
89/336/EEC AND SUBSEQUENT AMENDMENTS 92/31/EEC, 93/68/EEC AND 93/97/EEC.

PLACE AND DATE OF ISSUE
Casalfiumanese, 01/10/1997

SIGNATURE
General manager
Ing. Pietro CASELLI



EC DECLARATION OF CONFORMITY

Elettronica Santerno S.p.A.
Via G. Di Vittorio, 3 - 40020 Casalfiumanese (BO) - Italy

AS MANUFACTURER

DECLARE

UNDER OUR SOLE RESPONSABILITY

THAT THE MONODIRECTIONAL HALF-CONTROLLED SINGLE PHASE AC/DC CONVERTER
OF **AMS90/1** TYPE, TO WHICH THIS DECLARATION RELATES,
CONFORMS TO THE FOLLOWING STANDARDS OR NORMATIVE DOCUMENTS:

EN60146-1-1	Semiconductor convertors. General requirements and line commutated convertors. Part 1-1: Specifications of basic requirements.
IEC146-1-2	Semiconductor convertors. General requirements and line commutated convertors. Part 1-2: Application guide.
EN60146-1-3	Semiconductor convertors. General requirements and line commutated convertors. Part 1-3: Transformers and reactors.
IEC146-6	Semiconductor convertors. Part 6: Application guide for the protection of semiconductor convertors against overcurrent by fuses.
IEC664-1	Insulation coordination for equipment within low-voltage systems. Part 1: Principles, requirements and tests.
IEC22G/22/CDV	Power electronics. Semiconductor power convertors for adjustable speed electric drive systems. General purpose adjustable speed d.c. drive systems.
EN60204-1	Safety of machinery. Electrical equipment of machines. Part 1: General requirements.
EN60204-1 Amendment 1	Electrical equipment of industrial machines. Part 2: Item designation and examples of drawings, diagrams, tables and instructions.
EN60529	Degrees of protection provided by enclosures (IP Code).
prEN50178	Electronic equipment for use in power installations.

FOLLOWING THE PROVISIONS OF LOW VOLTAGE DIRECTIVE 73/23/EEC AND SUBSEQUENT
AMENDMENT 93/68/EEC.

LAST TWO DIGITS OF THE YEAR IN WHICH THE CE MARKING WAS AFFIXED: **97**

PLACE AND DATE OF ISSUE
Casalfiumanese, 01/10/1997

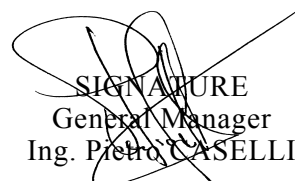
SIGNATURE
General Manager
Ing. Pietro CASELLI

MANUFACTURER'S DECLARATION

Elettronica Santerno S.p.A.
Via G. Di Vittorio, 3 - 40020 Casalfiumanese (BO) - Italy

AS MANUFACTURER

DECLARE

UNDER OUR SOLE RESPONSABILITY

THAT THE MONODIRECTIONAL HALF-CONTROLLED SINGLE-PHASE AC/DC CONVERTER
OF **AMS90/1** TYPE, TO WHICH THIS DECLARATION RELATES, APPLIED UNDER
CONDITIONS SUPPLIED IN THE USER'S MANUAL,
CONFORMS TO THE FOLLOWING STANDARDS OR NORMATIVE DOCUMENTS:

EN60204-1	Safety of machinery. Electrical equipment of machines. Part 1: General requirements.
EN60204-1	Electrical equipment of industrial machines.
Amendment 1	Part 2: Item designation and examples of drawings, diagrams, tables and instructions.

AND MUST NOT BE PUT INTO SERVICE UNTIL THE MACHINERY INTO WHICH IT IS TO BE
INCORPORATED HAS BEEN DECLARED IN CONFORMITY WITH THE PROVISIONS OF
MACHINERY DIRECTIVE 89/392/EEC AND SUBSEQUENT AMENDMENTS 91/368/EEC,
93/44/EEC AND 93/68/EEC.

PLACE AND DATE OF ISSUE
Casalfiumanese, 01/10/1997

SIGNATURE
General Manager
Ing. Pietro CASSELLI

